

Emergency Button Kit

Installation Guide

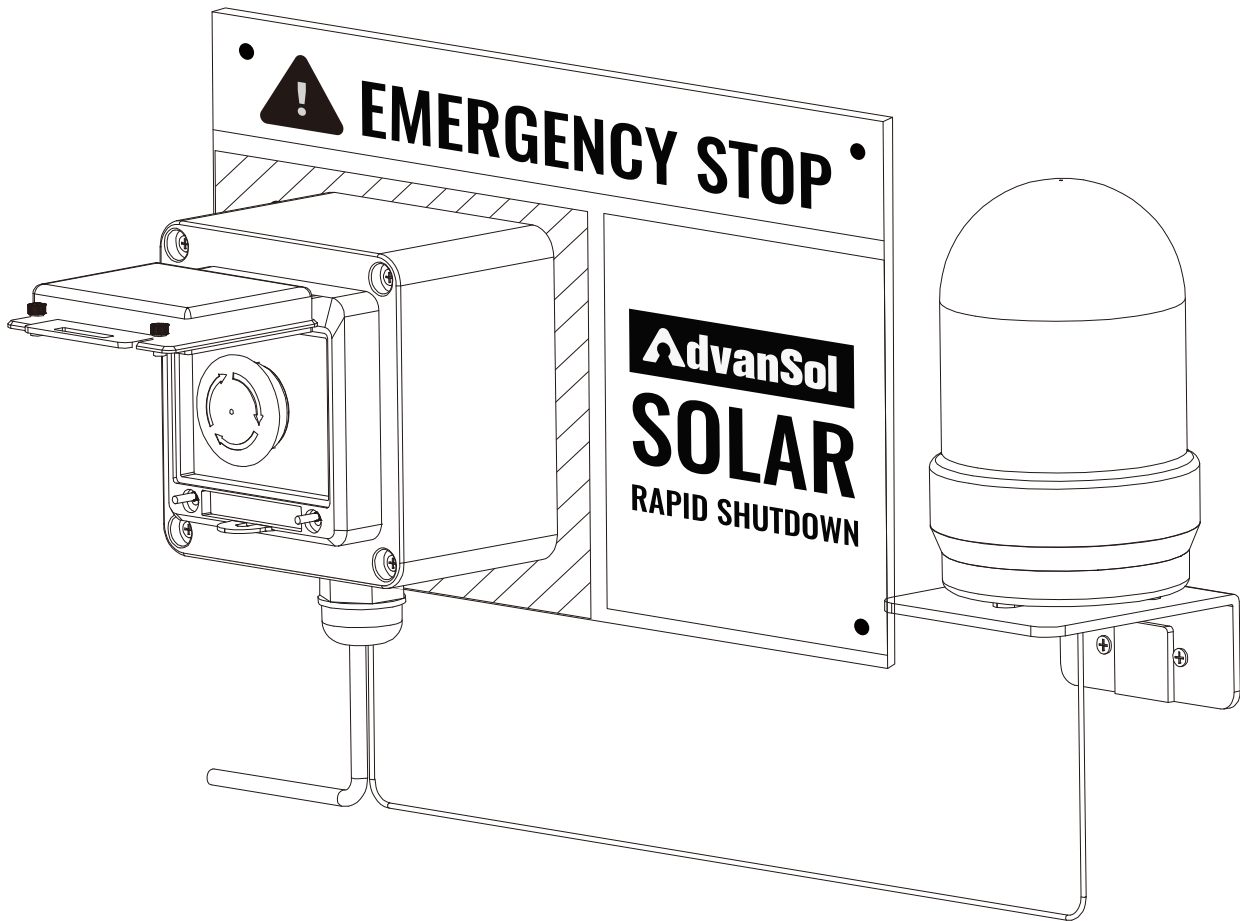

Note: Please strictly follow this guide for installation and operation, otherwise the performance and warranty may be affected by some wrong operations.

1. Packing List

Installation and Debugging Documents

Installation Guide for Emergency Stop Kit

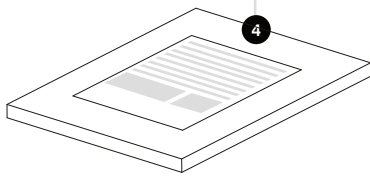

Warning Backboard

The warning backboard is embedded in the sponge.

Do not forget to take out or abandon

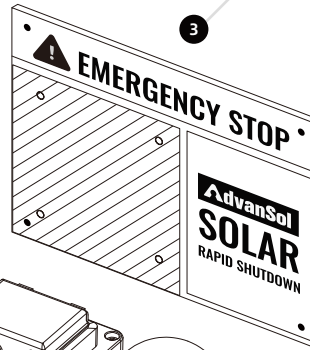

Emergency Button

The emergency stop button has been connected to the alarm light.

Please note not to drag it forcefully when taking it out.

to avoid the cable from falling off

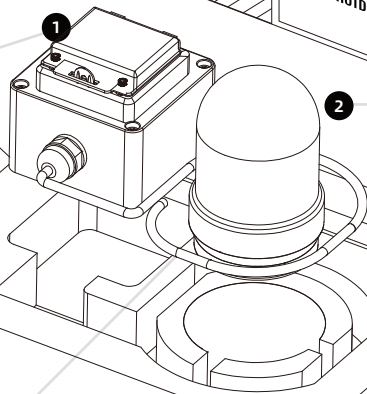

Alarm light

The alarm light has been connected to the emergency stop button

Please take them out at the same time

AC cable

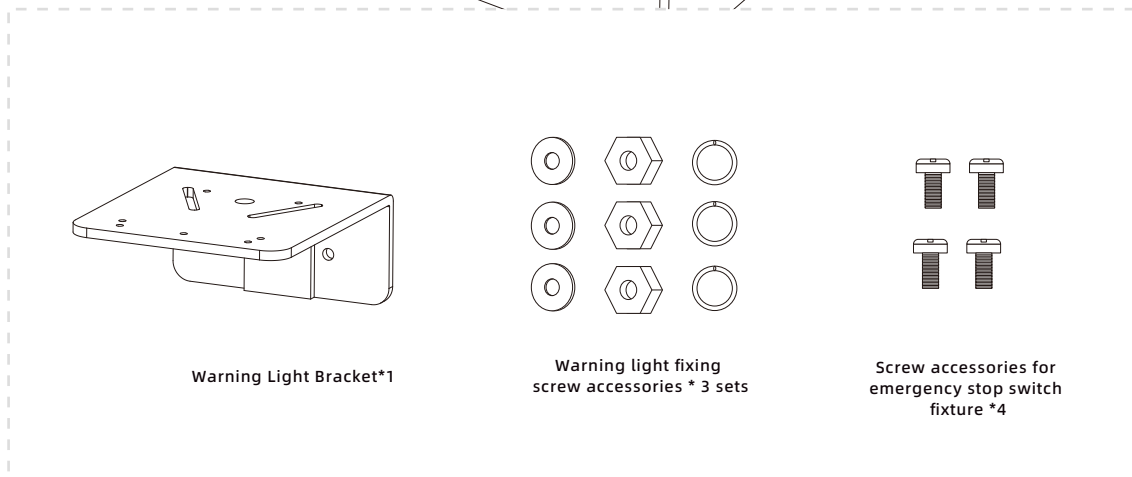

Warning Light Bracket*1

Warning light fixing screw accessories * 3 sets

Screw accessories for emergency stop switch fixture *4

2. Installation Procedures

- 1 Install the emergency stop switch with bolts at the four openings on the left side of the warning board.

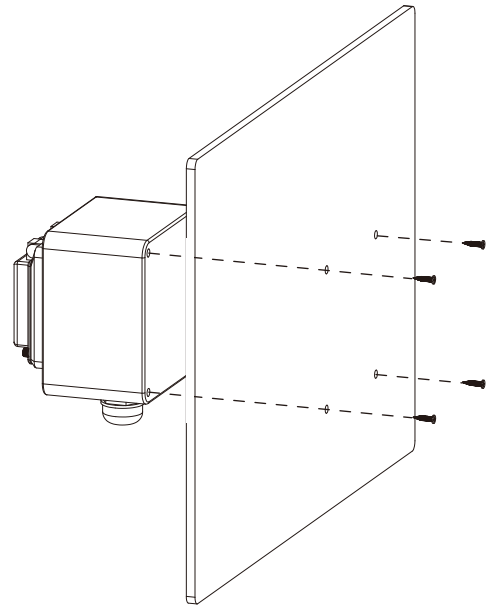
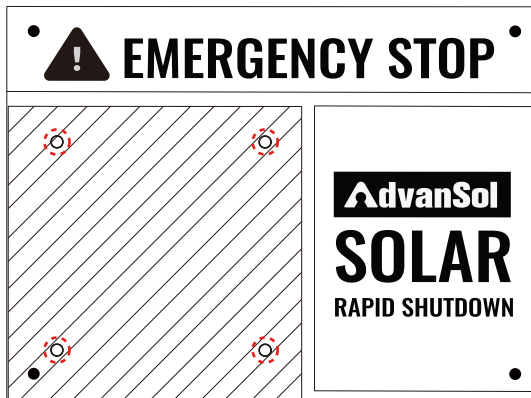

- 2 Fix the warning light on the bracket with screws.

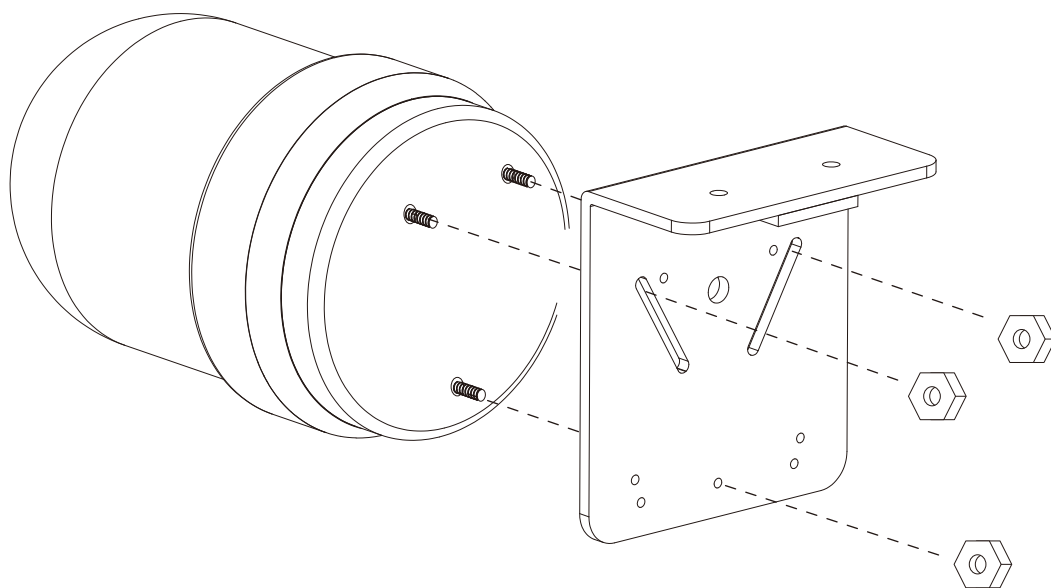

- ③ Fix the warning board with the emergency stop switch in the appropriate position. Please drill holes for fixation according to the actual fixing position.

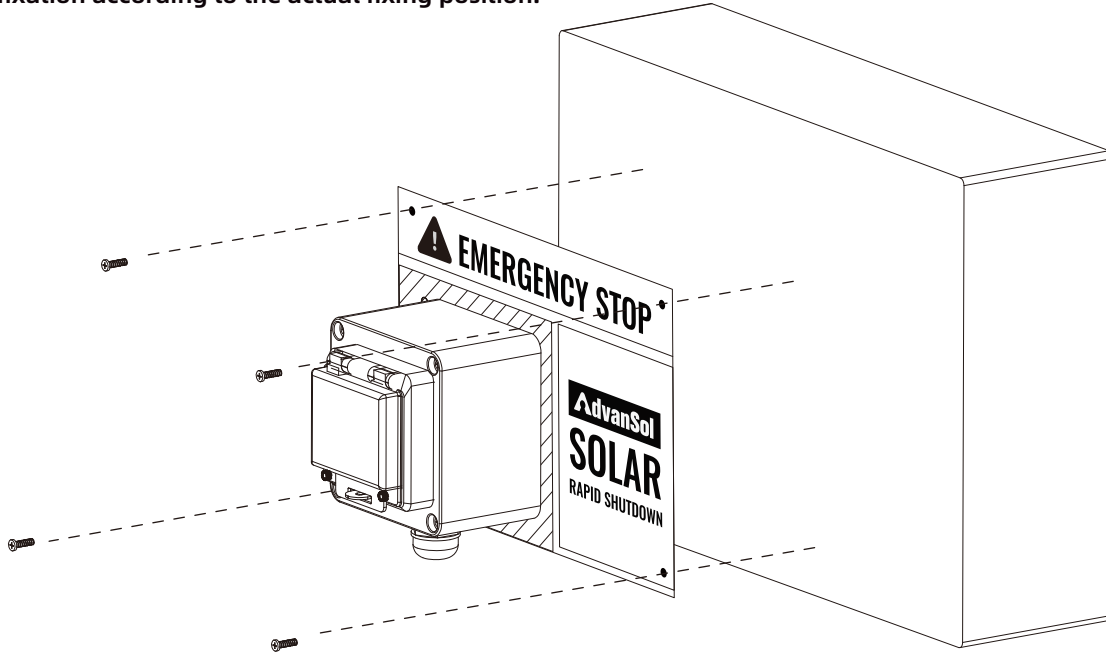

- ④ Fix the bracket with warning lights in the appropriate position.

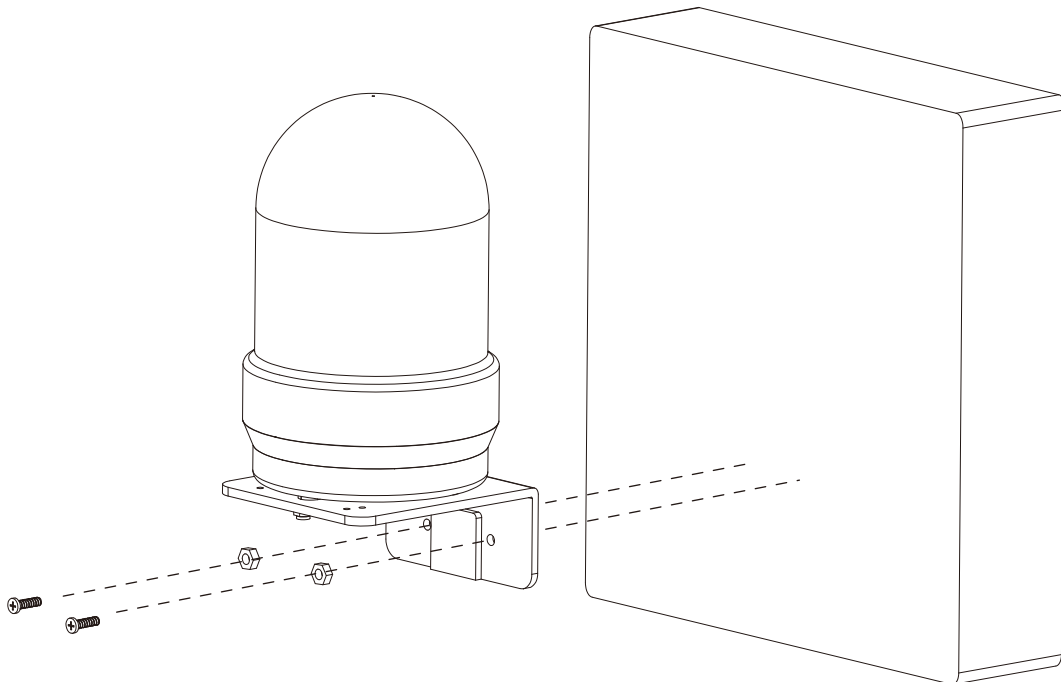

5 Connect the three sets of reserved cables of the emergency stop switch correctly.

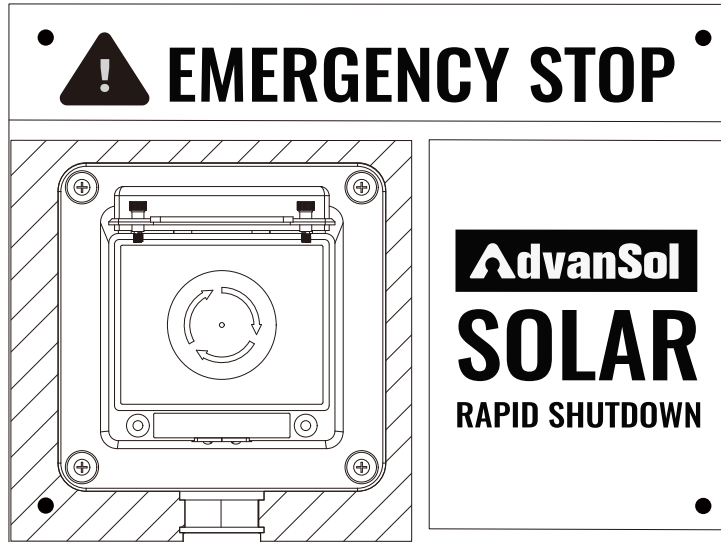

5.1 100 - 240V AC input

Cable Specification: 1.5mm²

Connector according to the requirements
Extend the cable length by yourself

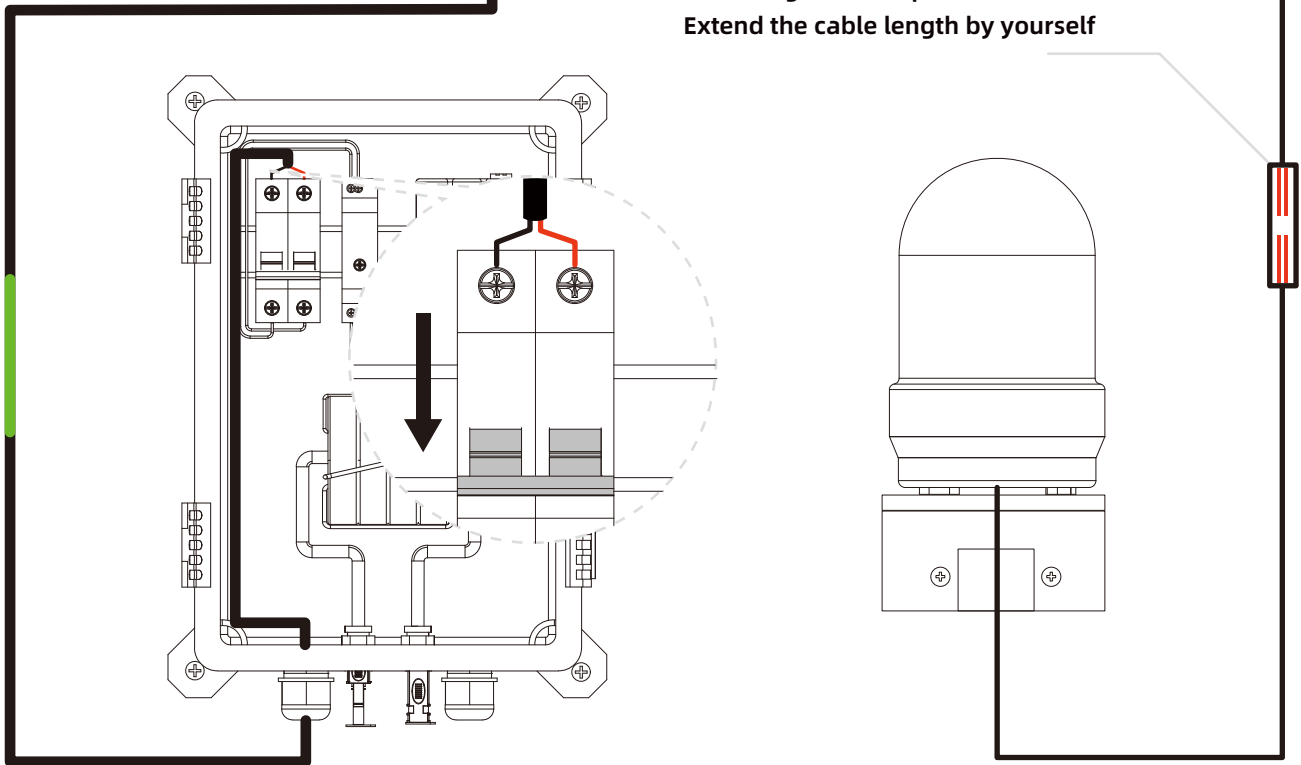

5.2 Connect the cable marked with a green sleeve to the upper end of the circuit breaker in the data control box.

When wiring, keep the circuit breaker in the off state.

⚠ If there are multiple control boxes for a single project, please connect the cables in the emergency stop device that are connected to the circuit breaker of the control box in parallel to the upper end of the circuit breaker in each control box.

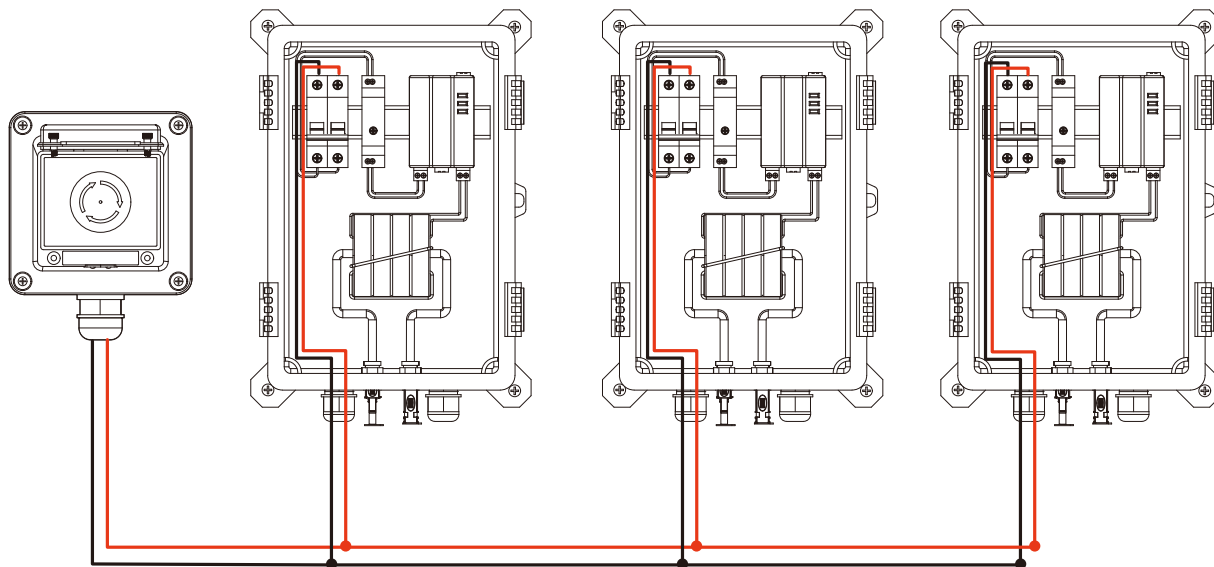

3. Installation Verification

After the installation and debugging of all devices are completed, test the emergency stop and shutdown function.

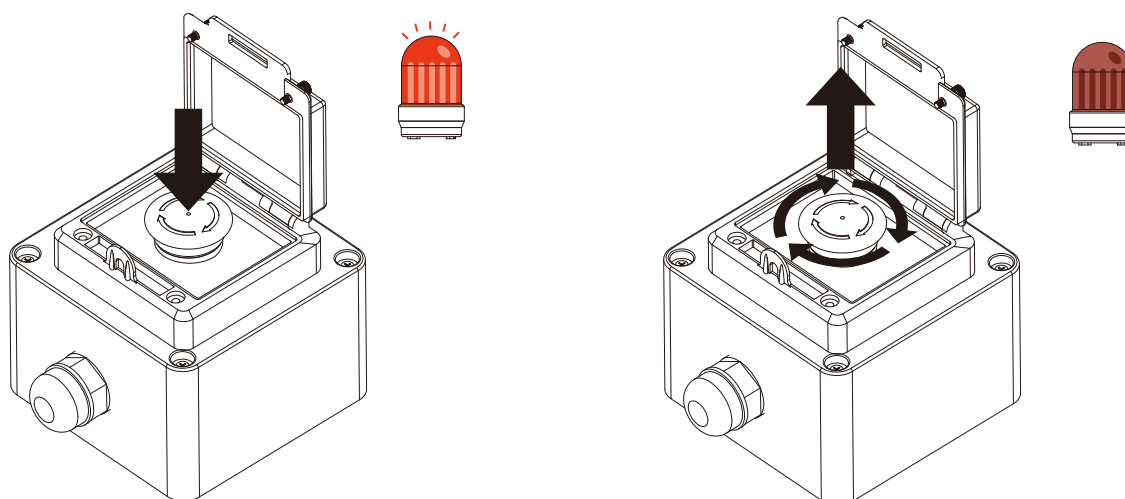

1 Please close the circuit breaker; press the emergency stop button, and the emergency stop warning light will keep flashing. The PWR indicator light of the data controller in the connected data control box will remain off. The current of its subordinate strings will drop to approximately 0A within 30 seconds.

2 When the emergency stop button is restored, the emergency stop alarm light will go out; the PWR indicator light of the data controller in the connected data control box will remain on; after the inverter completes self-check, the current of its subordinate strings will return to normal.

Contact us

If you have any technical questions on AdvanSol products, or need other language files, please contact us for help.

AdvanSol Power Technology Co.,Ltd

8 Floor, Building 2, 36 Zijing Street, Wuzhong District,
Suzhou City, China

☎ +86-512-662352

🌐 www.advansol-power.com

✉ service@advansol-power.com



Friendly reminder: Please scan the QR code to access versions in other languages.