

V2.5 Control Box DCON-WIFI ASP Small/Large

INSTALLATION GUIDE

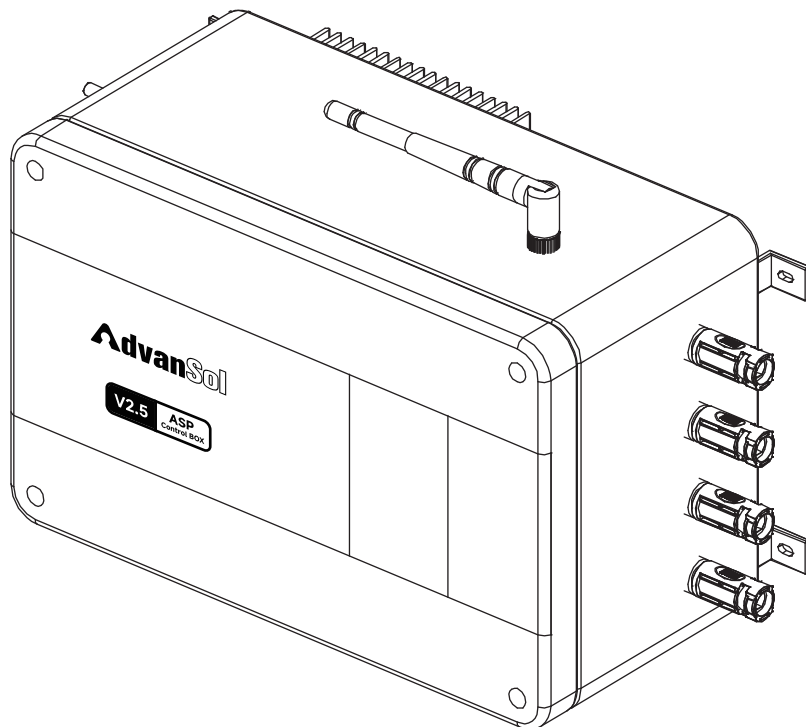

The Installation and Verification of V2.5 system control (Solution MRO/MR)

Installation and Verification
MRO/MR Series Micro controller



Installation and Verification of
V2.5 Control Box DCON-WIFI-ASP S/L



Solution MRO/MR
System Setting

Note: Please strictly follow this guide for installation and operation, otherwise the performance and warranty may be affected by some wrong operations.

1. Packing List

1 V2.5 Data Control Box DCON-WIFI-ASP
Small/Large Main Body

2 Protective Sponge

When discarding, please check that all
QC - MC4 terminals have been removed

3 Installation and
Commissioning Documents

1. MC Layout Diagram
2. Installation Guide of
V2.5 Control Box
DCON-WIFI ASP
3. Solution MRO/MR
System Setting

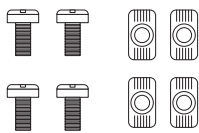
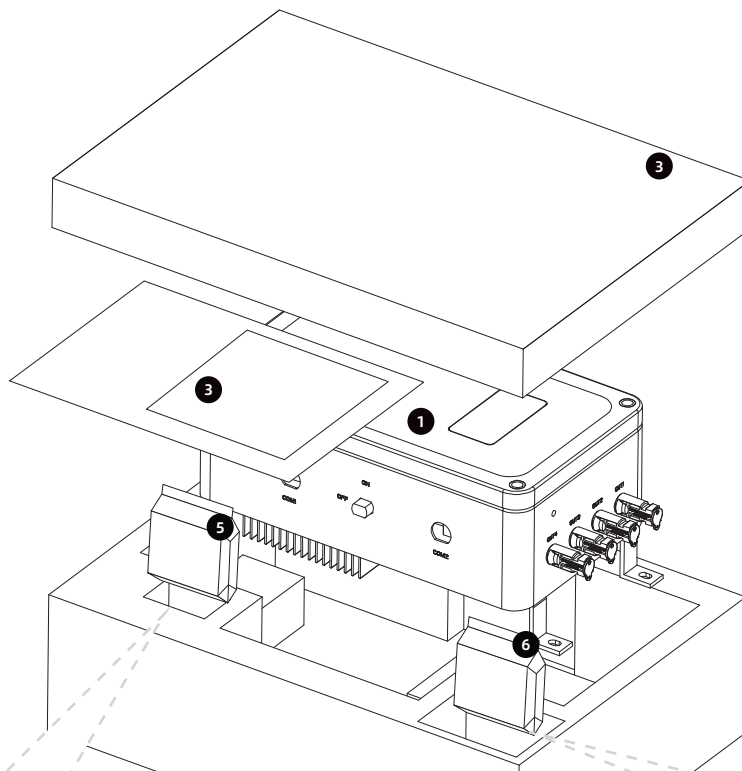

**Fixed Component
Screws *4**

Screws with Nuts:
4 pairs in total

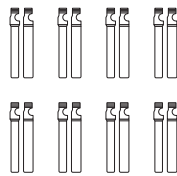

**QC - MC4
Terminal Pins**

S: 4 pairs L:12 pairs

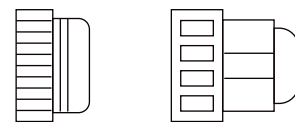

**AC cable connector*1
Waterproof connector*1**

Use when connected to COM1

2. Product Introduction

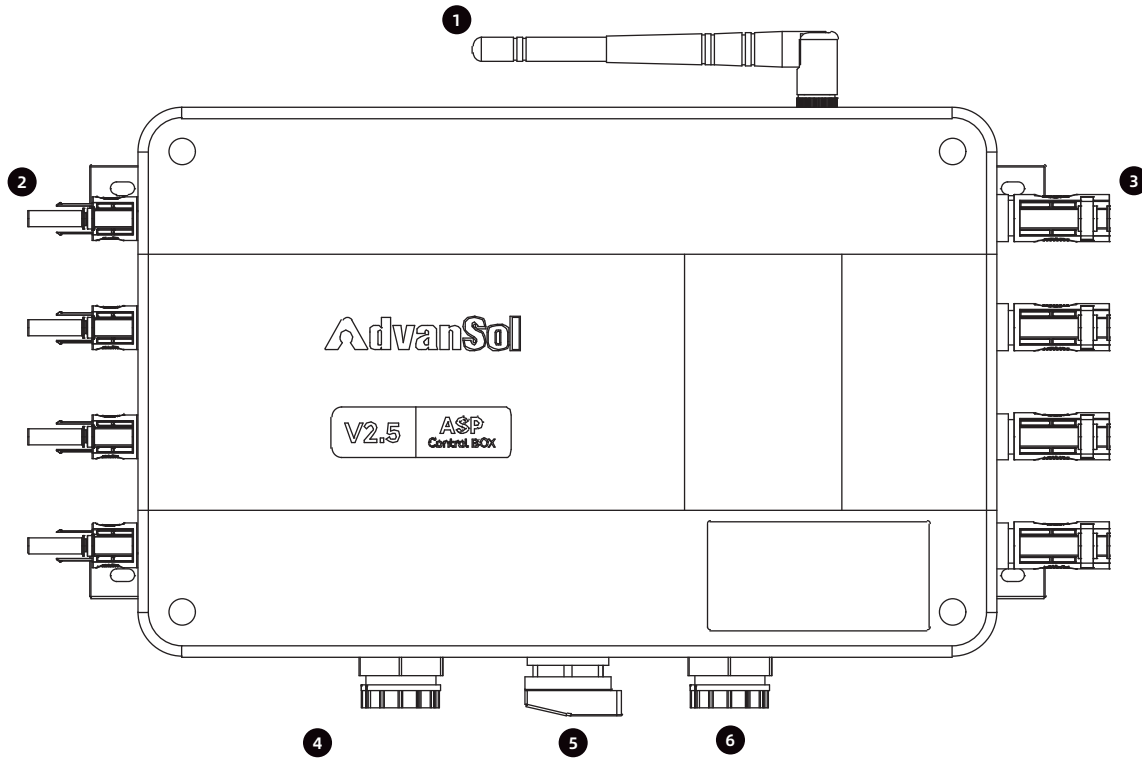

1 Antenna

The antenna has been connected inside the control box.
Avoid pulling when taking it out.
S: 1 piece L: 2 pieces

2 QC - MC4 Terminal Male

S: 4 pairs L: 12 pairs

3 QC - MC4 Terminal Female

S: 4 pairs L: 12 pairs

4 COM1 (AC power supply interface)

Connect the 100 - 240V AC power supply to the COM1 AC power supply interface

5 Breaker

Power breaker

6 COM2 (LAN port)

If there is no WIFI on site, you can connect the network cable

3. Installation Requirements

1 Please install the micro controller first, and then install the V2.5 Control Box DCON-WIFI ASP

2 When the system is running correctly, the PWR and TX/RX lights are on and the LIE light is flashing;

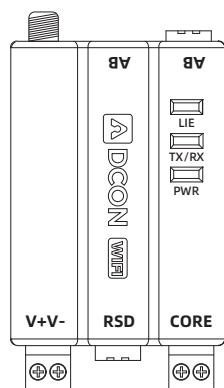
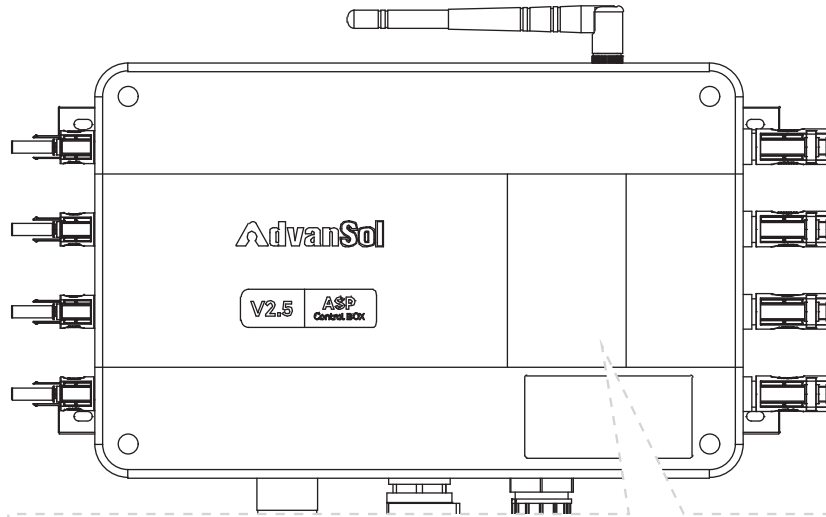

APT-DCON-WIFI

No.	1	2	3
Type	WIFI	PLC	Power
Color	Blue	Green	Red
On	/	On	Power up
Off	Disconnected	Off	Power off
Flash	Connected	/	/

3 The communication distance between the V2.5 Control Box DCON-WIFI ASP and the farthest micro controller: the length of a single wire $\leq 300M$;

4 Please use the accessories of the V2.5 Control Box DCON-WIFI ASP with caution to avoid man - made damage;

5 Protective measures should be taken during installation before construction;

4. Installation Procedures

1. Before installation, ensure that the DC side of the inverter is turned off and the power supply of the data control box is switched off. Take protective measures before proceeding with the installation.

2. The data control box is installed on the DC cable between the photovoltaic inverter and the photovoltaic array, usually close to the inverter side.

- ① Use the screws provided in the package to fix the data control box on the bracket.
Or use other suitable screws to fix it on the wall by yourself.

- ② The QC - MC4 terminals on the side of the data control box correspond to the APT - DCON - WIFI data controller.

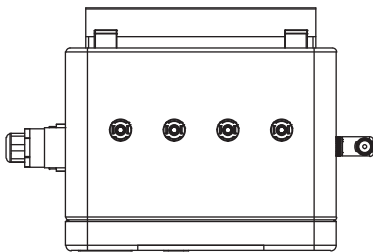

S: 1 group, can be connected to 4 strings of DC bus negative poles.

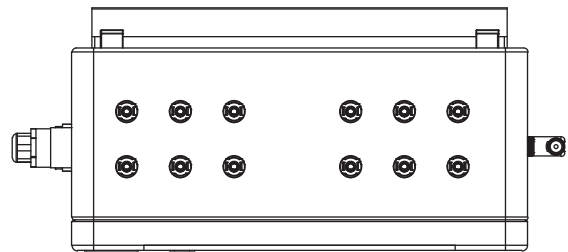

L: 2 groups, can be connected to 12 strings of DC bus negative poles.

The V2.5 Control Box DCON-WIFI ASP SN on the top surface of the V2.5 data control box corresponds to the QC-MC4 terminals on the side of the control box.

On the top surface of the box, there is a QR code label for the APT-DCON-WIFI data controller.

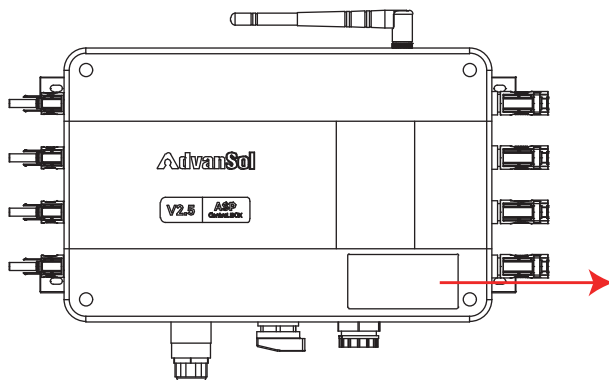

On the top surface of the control box, DCON_SN corresponds to the QC-MC4 terminals on the side of the control box.

S: 4 strings correspond to 1 DCON.

L: The upper 6 strings correspond to DCON #1, and the lower 6 strings correspond to DCON #2.

- Match each set of QC-MC4 terminals with the corresponding string; connect the positive pole of the DC bus directly to the inverter, connect the negative pole of the DC bus to the QC-MC4 terminal marked with IN on the side of the data control box, and then connect the negative pole of the DC bus to the inverter at the QC-MC4 terminal marked with OUT on the corresponding other side.

Note: Please pay attention to the IN/OUT markings and use the QC-MC4 terminals provided in the package.

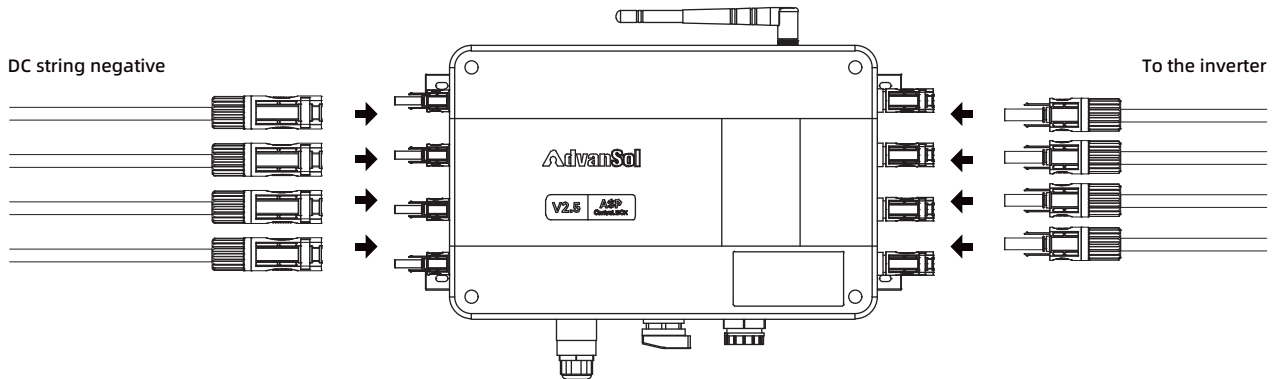

- Please check whether the antenna on the top of the data control box is properly fixed.

- After confirming that the AC power switch is in the off state, connect the 100 - 240V AC power supply to the COM1 AC power supply interface;

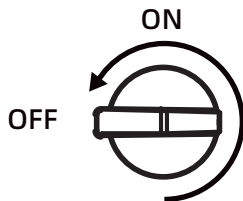

Steps: Pass the AC cable through the waterproof joint, and connect it to the AC cable joint (L/N can be connected arbitrarily).

After connection, please fix the waterproof joint and the AC cable joint as one unit, and fix them at the COM1 AC power supply interface.

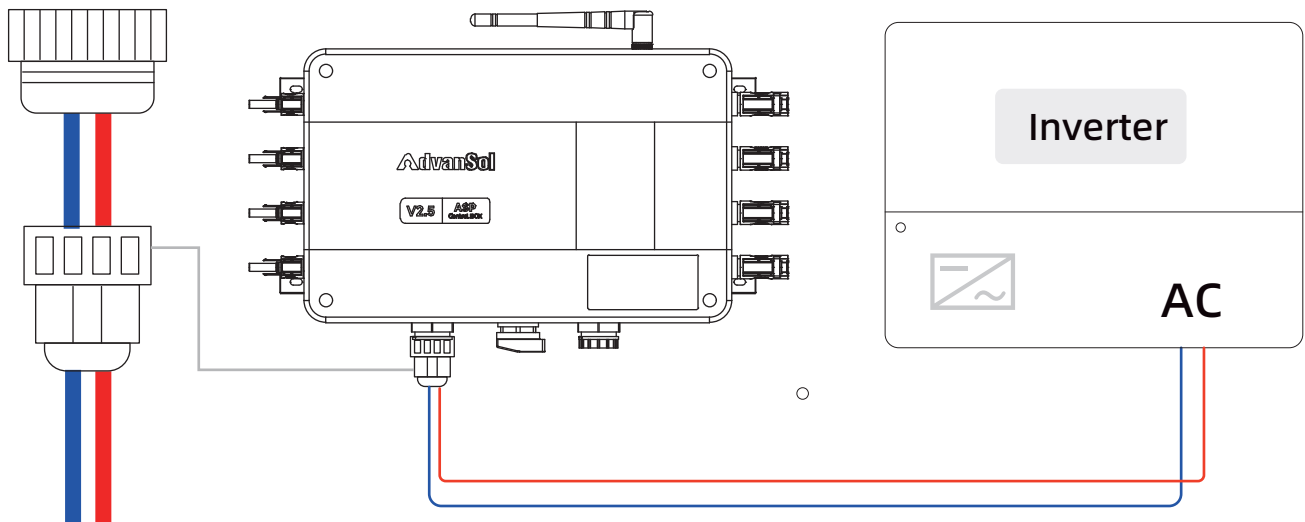

⑥ Stick the V2.5 Control Box DCON-WIFI ASP SN QR code on the MC Layout Diagram

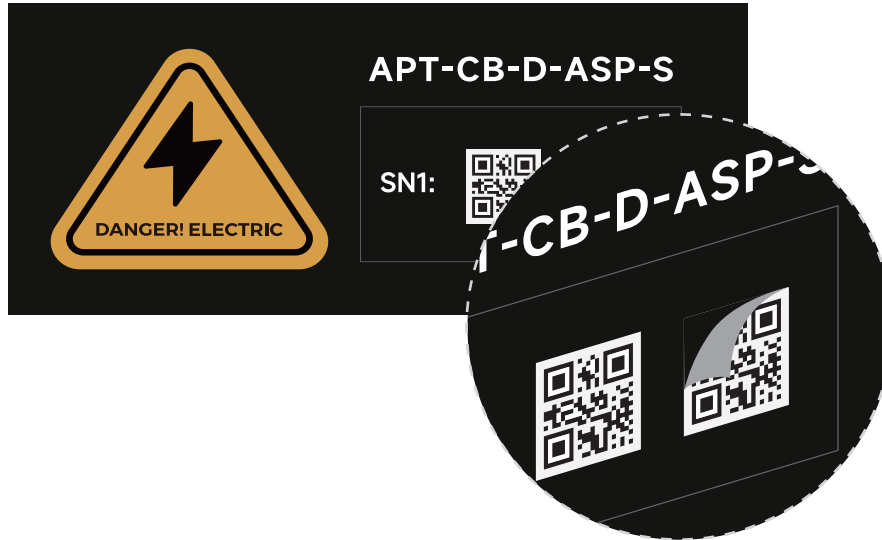

Tear off the DCON SN and stick it on the top left corner of the MC Layout Diagram

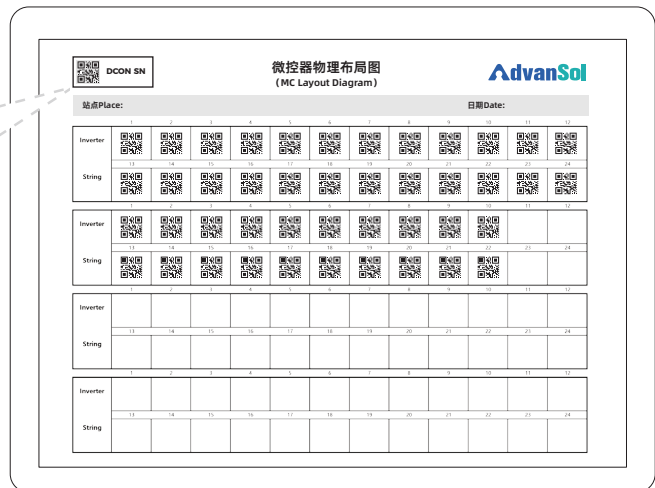

Note: The MC Layout Diagram is inside the packing box. Please go to AdvanSol website for copies if you lost it

AdvanSol Web-Download Center-Service Download
Center-The MC Layout Diagram
(https://www.advansol-power.com/ServicesDownload_en.html)

5.Installation Verification

- ❶ Please make sure the main body and all accessories of the box is well fixed
- ❷ Turn on the breaker, the PWR light of DCON-WIFI on

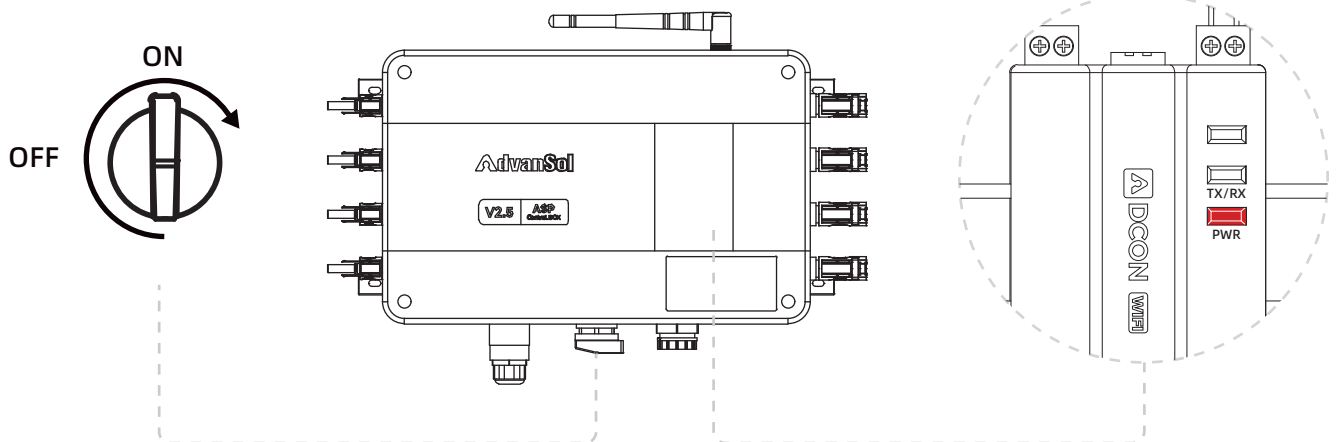

- ❸ Turn off the breaker, the PWR light of DCON-WIFI off

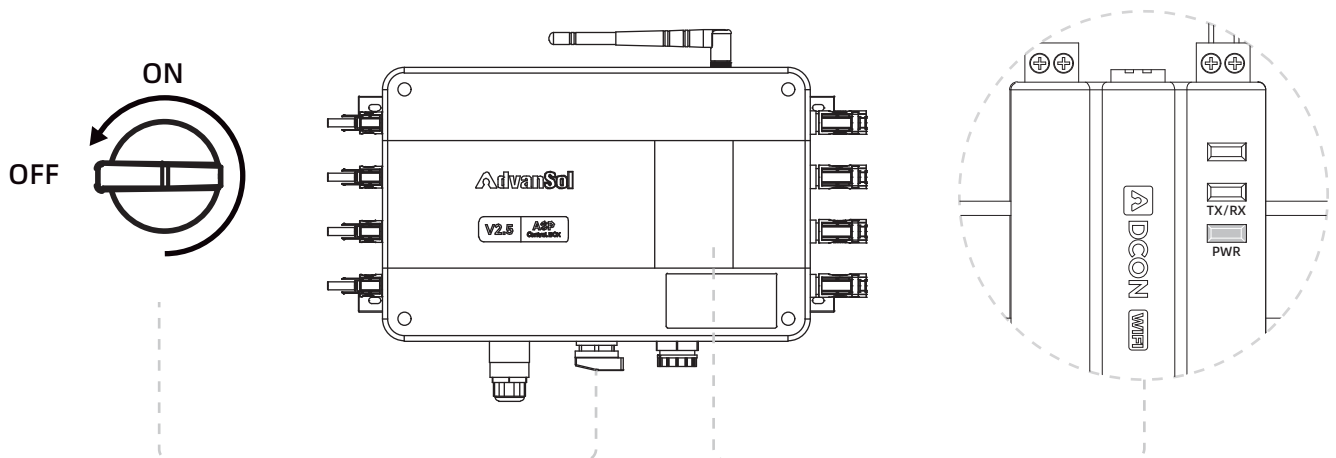

V2.5 Control Box DCON-WIFI ASP S/L is well installed.

Contact us

If you have any technical questions on AdvanSol products, or need other language files, please contact us for help.

AdvanSol Power Technology Co.,Ltd

8 Floor, Building 2, 36 Zijing Street, Wuzhong District,
Suzhou City, China

☎ +86-512-662352

🌐 www.advansol-power.com

✉ service@advansol-power.com



Friendly reminder: Please scan the QR code to access versions in other languages.